

bluEvolution 82

Classic design combined with
outstanding energy efficiency



Windows are always unique and a key value-adding factor

Windows make up just a small percentage of the construction costs yet have a major impact on the home:

- Windows which match the style of the building give the home a face and increase the value of the property.
- Daylight enhances the ambience in the home and has a positive effect on physical and mental well-being.
- The energy input of well-insulated windows acts like a heating system.
- Between 25 and 50 % of heating costs and the associated environmental and CO₂ pollution can be reduced thanks to modern windows.
- Windows help to ensure optimal control of the room climate.
- The right windows can slash the risk of burglary by 80 %.
- Noise pollution from the outside can be reduced by up to 75 % in urban regions with suitable windows.

The site, building and residents are all unique. Therefore, there is no such thing as a perfect standard window solution to suit all demands. Assessing the price alone is not enough to make a sound decision. Windows must be configured to the specific requirements to become the perfect "myWindow".



Tactile surfaces transform windows into a haptic interior design experience

In this Premium line we combine our experiences acquired from many decades of profile development: technology meets timeless design. The Greta®Fenster combines the advantages of ecological performance and PVC window profiles with absolute design standards.

Produced for maximum sustainability, the material used is 100 % sourced from old windows and production rejects, and is itself in turn 100 % recyclable. At the same time, with the specially developed recipe we create a modern, monochrome texture in concrete look. This makes the window a unique design object with haptic experience.

With our Greta®Fenster product, for the first time ever, we won one of the most important design prizes: the German Design Award in the "Excellent Product Design – Eco Design" category as well as the Rot Dot Award in the "Product Design" category. For us, sustainability and design go hand in hand – for a better and livable future.

Greta®Fenster

Outer surface - the same as the inner surface



Texture produced from
100 % recycled PVC

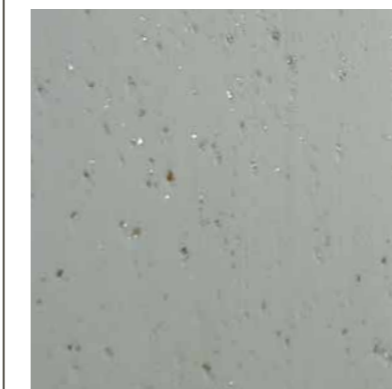

Light grey

The Salamander C3 principle: The route to the optimum configuration

Thanks to our specially developed processes, you are guaranteed to find the window that meets your specific demands. These three dimensions are central in determining whether your choice suits the building and external influences:

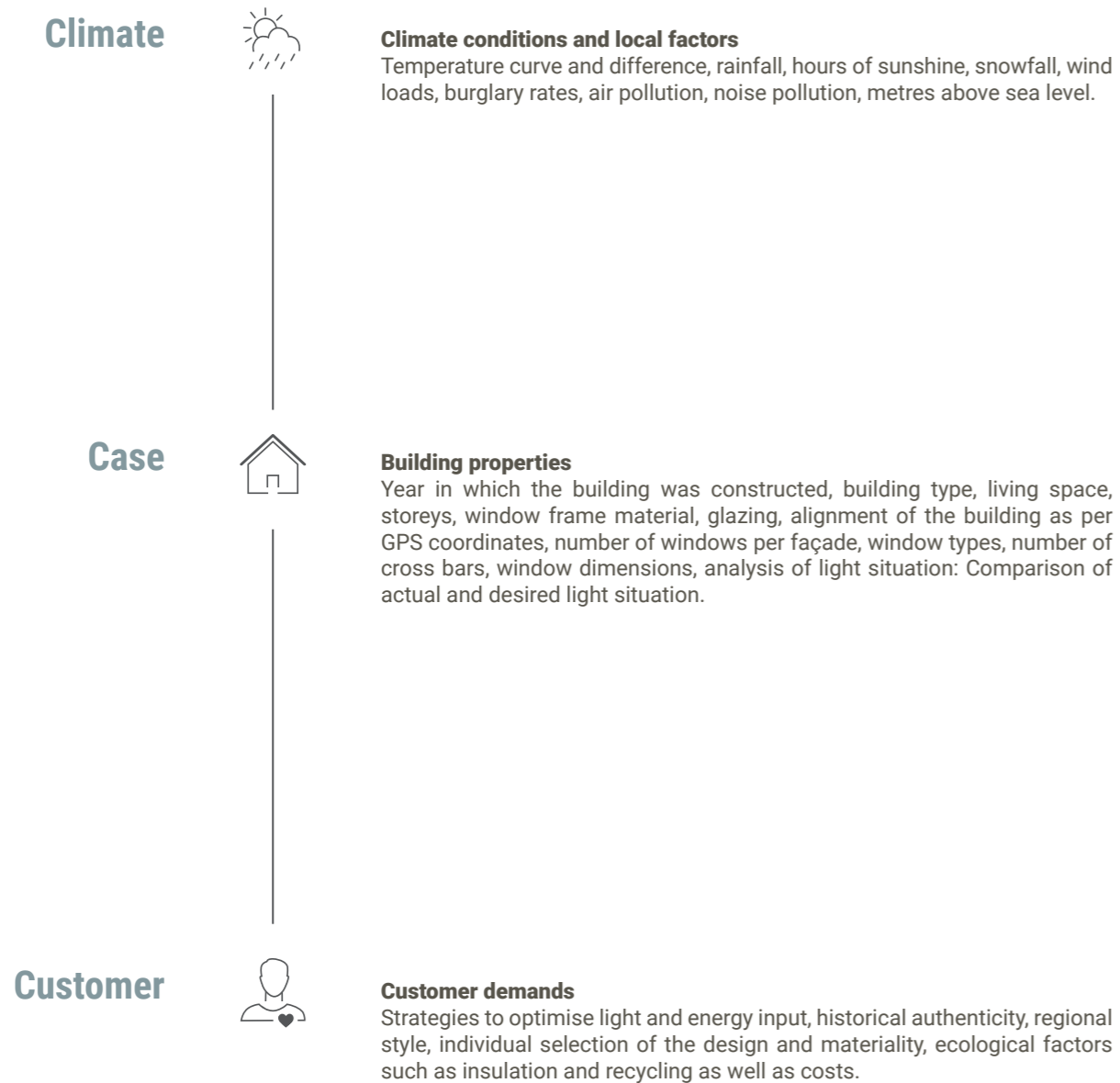

Climate

bluEvolution 82 offers efficient options for energy conservation and innovative gasket technology of the highest order. It is thus an ideal component for the construction of passive houses. With the special

thermally-optimised frame and sash constructions together with thermally insulating triple glazing and integrated thermally-improved edge seal, a heat transfer coefficient of $U_f = 0,98 \text{ W}/(\text{m}^2\text{K})$ can be

achieved. As such, optimal heat and energy savings are ensured.

Case

Building style

Thanks to its classically offset appearance, bluEvolution 82 can be optimally adapted to the individual architectural style. A round sash variant is also available.

Structural analysis

In the standard version, window sizes of 2.50 m can be realised, thus covering all common construction sizes.

Light

The window sizes which can be achieved with bluEvolution 82 ensure optimal light input.

Alignment

Given the optimised thermal insulation values and high light input, bluEvolution 82 is able to improve the energy balance even on North-facing façades.

Customer

Sound insulation

Sound protection of up to 47 dB can be achieved with glazing thicknesses of up to 52 mm.

Burglar protection

With bluEvolution 82, burglar protection of up to RC2 can be achieved using standard measures.

Surfaces

Brüggmann White, base material alternatively anthracite, brown and caramel more than 40 standard film decors as well as customised aluminium covers.

Additional surfaces

Greta®Fenster

The most important values at a glance

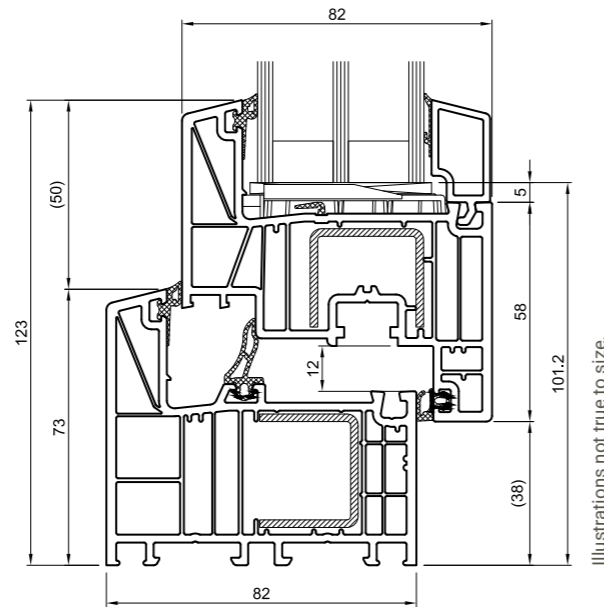

Central gasket system:

- Intelligent gasket technology for optimal energy efficiency
- Ideal components for passive houses
- Exceptional thermal insulation with optimal triple glazing and integrated thermally improved edge seal

Thermal insulation	MD up to $U_f = 0,98 \text{ W}/(\text{m}^2\text{K})$ up to $U_w = 0,73 \text{ W}/(\text{m}^2\text{K})$ AD up to $U_f = 1,10 \text{ W}/(\text{m}^2\text{K})$ up to $U_w = 0,77 \text{ W}/(\text{m}^2\text{K})$
Sound insulation	47 dB
Safety	up to RC2
Construction depth	82 mm
View height	107/123 mm
Maximum sizes	Standard sash: Width up to max. 1,500 mm Height up to max. 2,500 mm Balcony door sash: Width up to max. 1,600 mm Height up to max. 2,500 mm Front door sash: Width up to max. 1,200 mm Height up to max. 2,400 mm
Types of opening	Turn, tilt, tilt and turn windows, lift&side entrance, folding and lift&slide doors, entrance door

The heat transfer coefficient U: In $\text{W}/(\text{m}^2\text{k})$.
The lower the U-value, the lower the heat loss in winter and the heat transmission in summer. U_f (frame) is the value of the frame and sash combination, U_w (window) that of the entire of the entire structure including the glazing.

*for U_g 0.5 with edge seal 0.03 and window element 1230 x 1480 mm

Subject to changes, errors, printing and type setting mistakes.

The ideal, more sustainable material – PVC

We specialise in the production of window profiles using the sustainable and long-lasting material PVC and combine this with our innovative surfaces. This enables you to create customised solutions which not only suit the style of the building, but also bring it to life – on the outside and inside.

Today, production at the Salamander Window & Door Systems sites in Türkheim and Włocławek (Poland) is completely powered by green electricity.

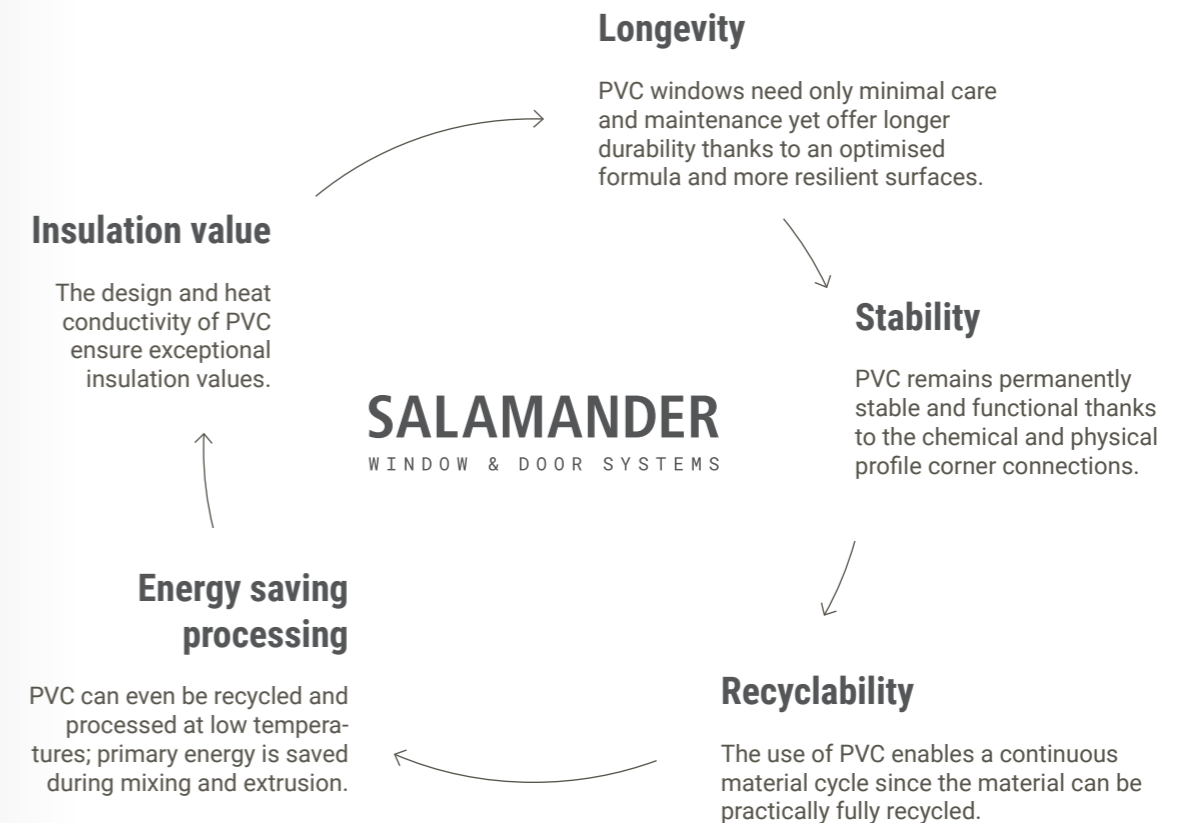

SALAMANDER

WINDOW & DOOR SYSTEMS



We have the perfect doors and windows to suit your needs –

thanks to our decades of experience in profile development and PVC extrusion. Long-lasting, customisable and sustainable from the word go: We are continuously developing our systems to offer you the perfect window for the future, today.

Salamander Industrie-Produkte GmbH

Jakob-Sigle-Straße 58
86842 Türkheim
Germany

salamander-windows.com



2023-05 EN

